

Introduction

WONST

CO.,LTD.

LINEAR MOTION SYSTEM



Company Overview



Company

WONST CO.,LTD.

Established

Dec. 12. 1989

CEO

Teakwon Lee

Headquarter

224, Yuram-gil, Paltan-myeon, Hwaseong-si, Gyeonggi-do, Republic of Korea

Website

www.wonst.co.kr

Company History

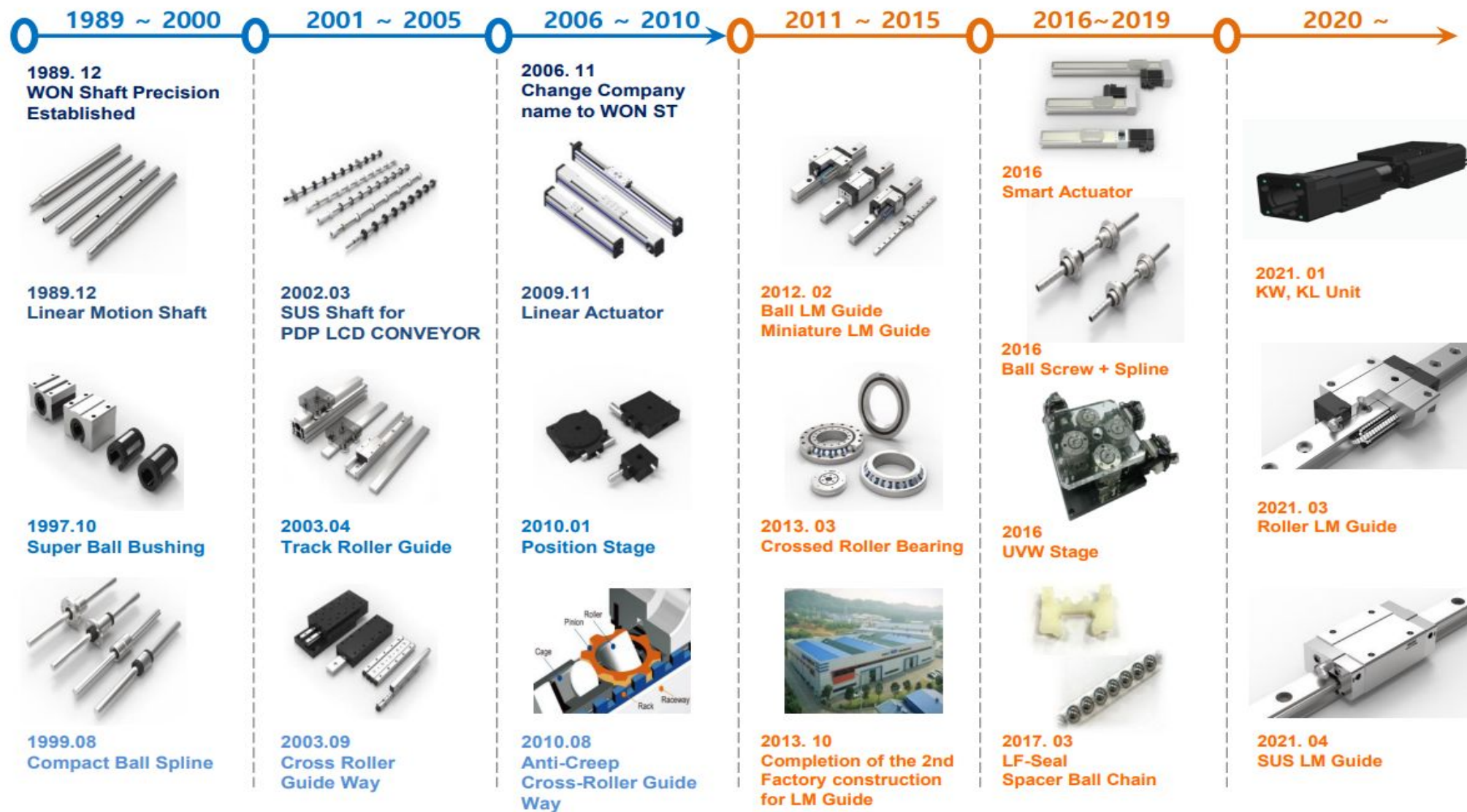

Company Introduction

High
Precision
Production

High
Technology
Heat-Treatment

Rolling
& Smooth
Movement

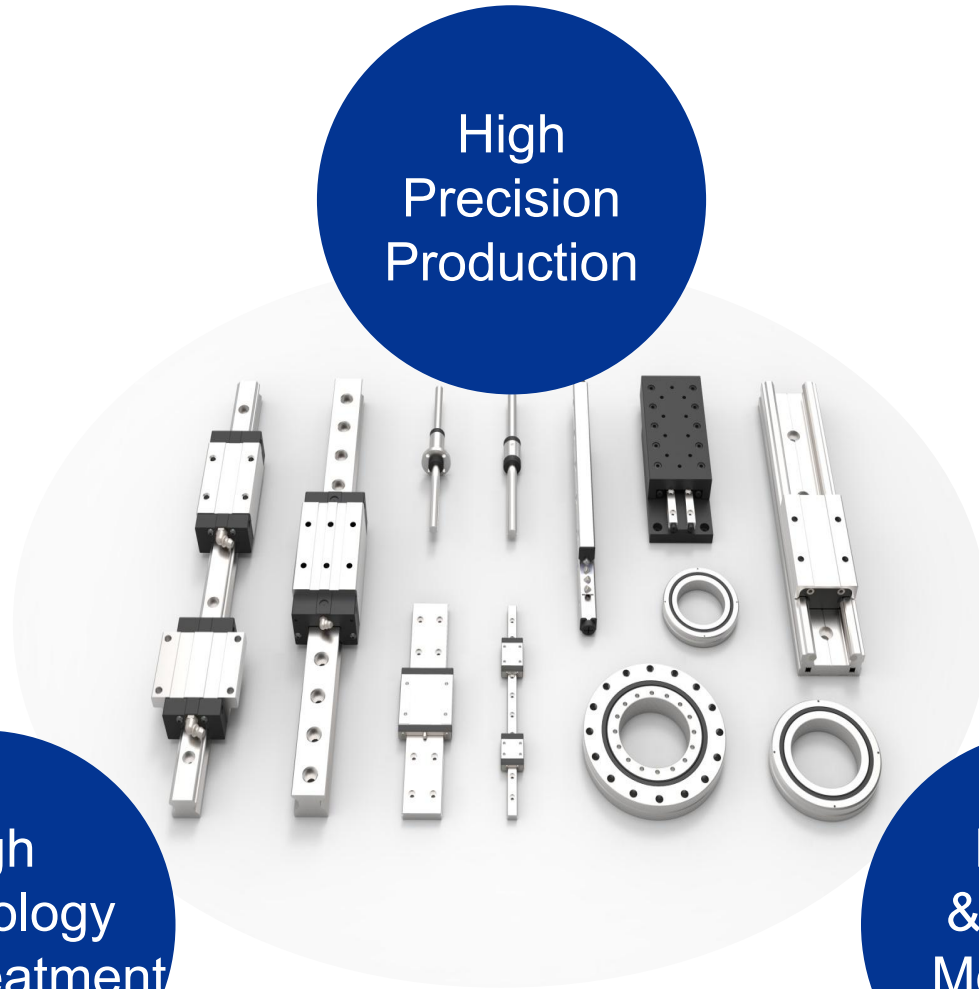

Product Introduction_Linear Motion Guide

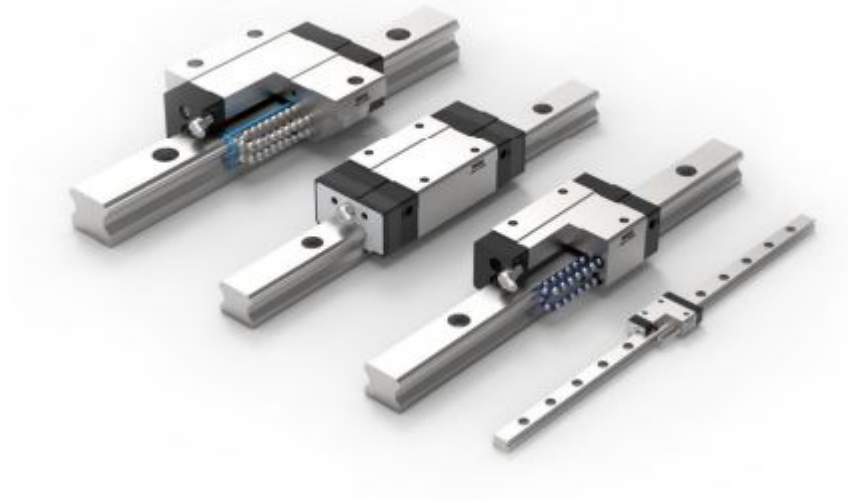

• Ball Type

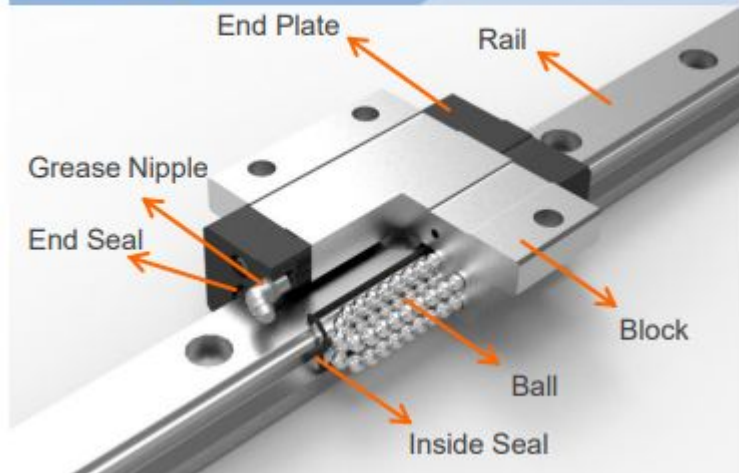

• Roller Type

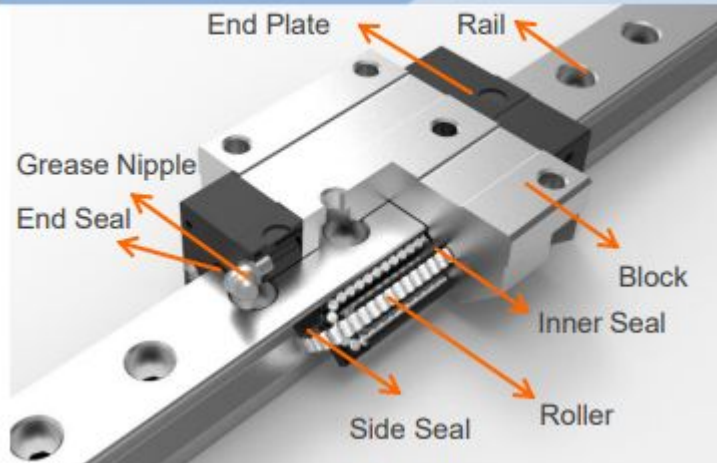

• 4-Direction Equal Load Type

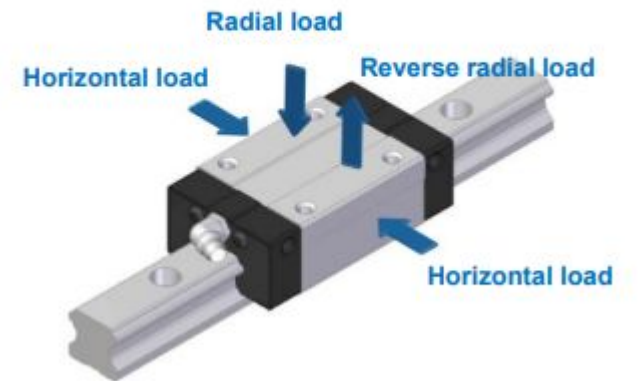

Product Introduction_Linear Motion Guide



※Applied

- ▶ Factory automation, Machine tool linear motion part
- ▶ Semiconductor facility, Linear motion part
- ▶ OLED / LCD production facility Linear motion part

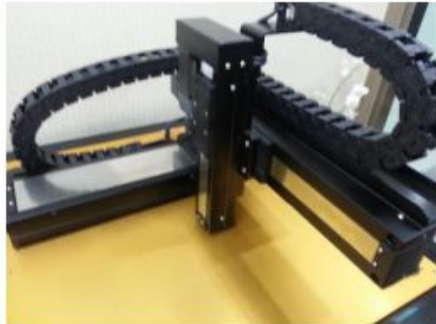

✓ Cartesian coordinates Robot



✓ Machine tools



✓ 3D Sculptor



✓ CNC Tapping center

Product Introduction_Crossed Roller Bearing



- 90° v groove and rollers as rolling elements are assembled in the v grooves.
- 4 times more rigidity than flat angular bearing.

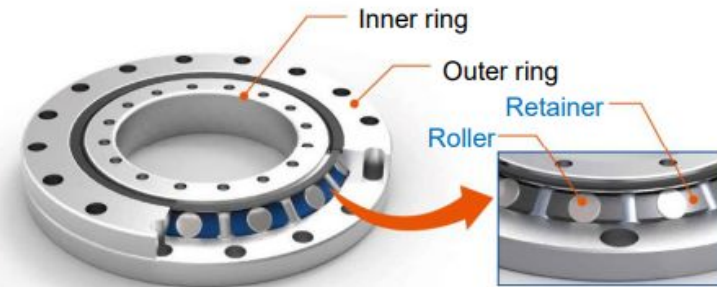

※Applied

- ▶ Machine tool Index Table, OLED / LCD transfer robot, Rotating part, etc

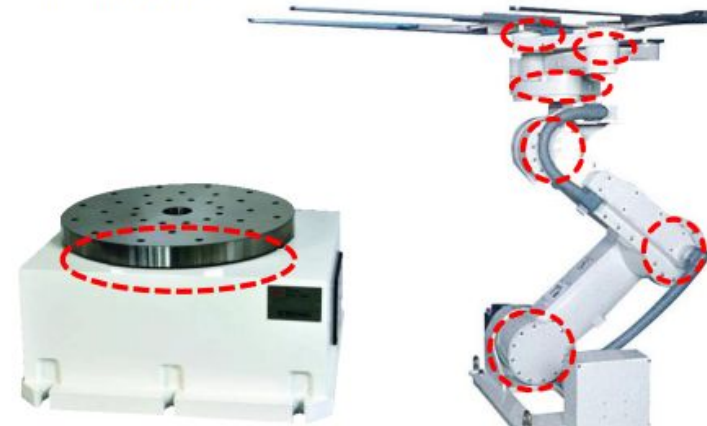

✓ Index table

✓ Articulated robot

Product Introduction_Ball Spline



Compact Ball Spline



Linear Ball Spline

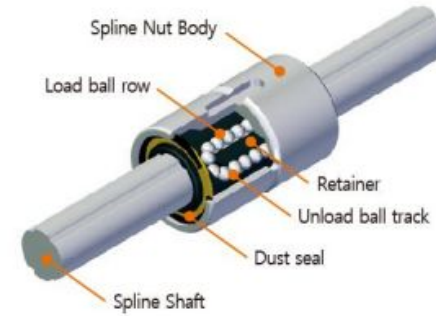

Applied

• The circumferential direction as linear movement system.

► Semiconductor, Robotics / Medical

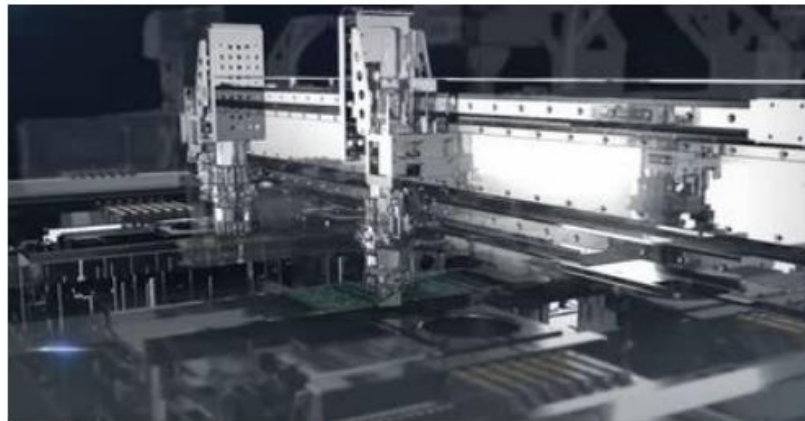

✓ Chip Mount



✓ Blood Analyzer

Product Introduction_Cross Roller Guide Way



- Precise rollers are assembled relatively reverse direction one by one in roller cage and used on between 90° V groove raceways..
- Low friction and smooth rolling movement

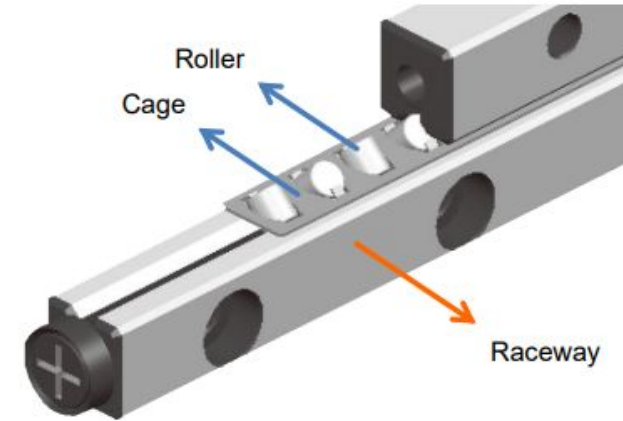

※Applied

- ▶ Precise inspection & Measuring facility Linear motion part, Industrial machine Linear motion part, etc



✓ Wire bonder

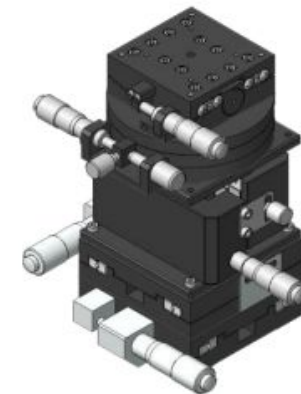

✓ Manual Stage App Ex

Product Introduction_FPD Conveyor Shaft



- All Options Available
- Compound material apply technology



✓ Magnet CONV. App Ex

▶ LCD Clean Conveyor Shaft

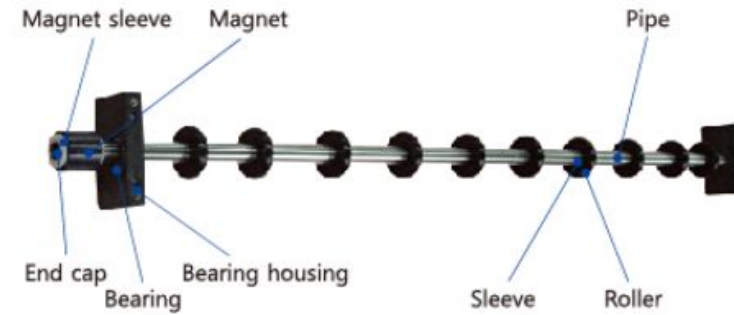

※Applied

- ▶ LCD Conveyor Shaft, Display part

▶ LCD Shaft for Cleaning

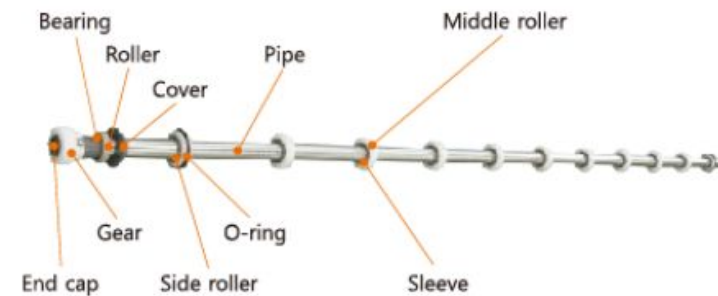

Product Introduction_Ball Bushing

Super Ball Bushing



- Dynamic load rating 3 times more and rolling life time 27 times more than normal Ball Bushing.

Linear Ball Bushing



- Infinite linear motion system assembled with cylindrical Linear motion shaft.

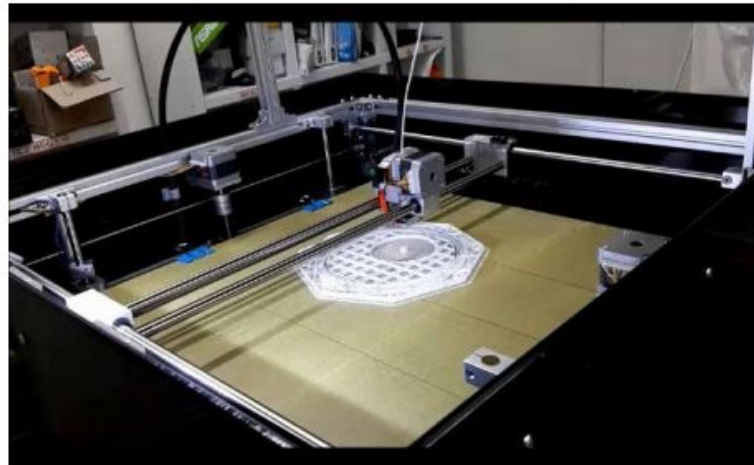

✓ Ball Bushing. App Ex

Slide Rail Unit

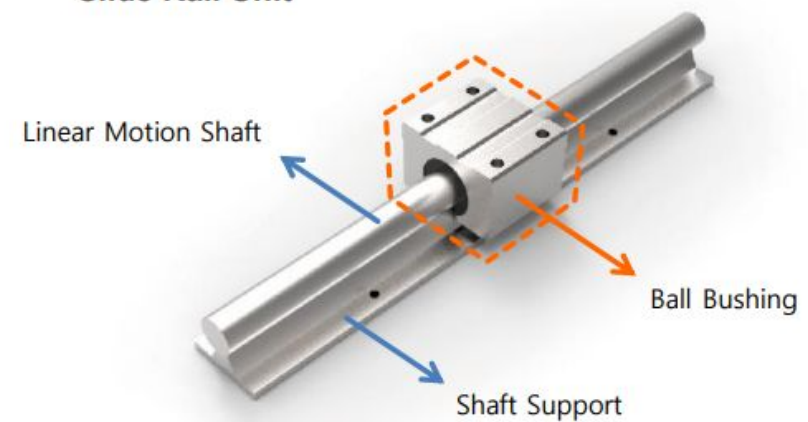

Product Introduction_Linear Motion Shaft



- High carbon chrome bearing steel(SUJ-2, STB-2)
- Martensite stainless steel(SUS440C)
- STB-2 HRC60 ~ HRC64
- SUS440C HRC54 ~ HRC56

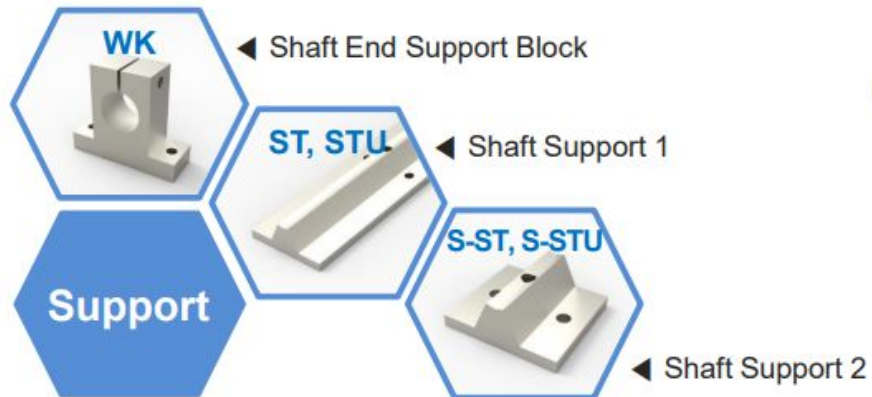

※Applied

- ▶ Slide Rail Unit, Pneumatic equipment, Factory automation, etc.

Slide Rail Unit

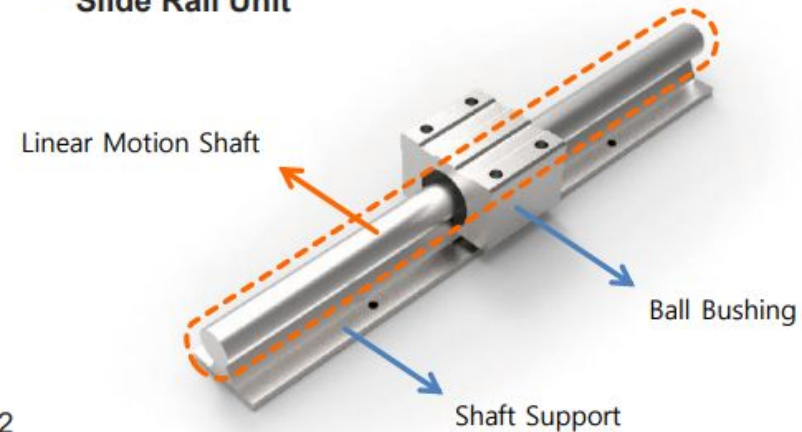

Overseas Sales Network



A sales network of 42 overseas and machine tools & semiconductor equipment manufacturers

Thank you!

LINEAR MOTION SYSTEM

